

THIS DRAWING IS PROTECTED UNDER COPYRIGHT LAW AND IS THE PROPERTY OF PERFORMANCE MACHINE INC. DATA CONTAINED HEREIN IS PROPRIETARY TO PERFORMANCE MACHINE INC. THIS DRAWING AND/OR ANY PART OF THE DATA CONTAINED HEREIN MAY NOT BE COPIED, DUPLICATED OR RELEASED FOR MANUFACTURING OR SALE OF EQUIPMENT OUTSIDE OF PERFORMANCE MACHINE INC. OR AFFILIATES WITHOUT THE WRITTEN CONSENT OF PERFORMANCE MACHINE INC.

REVISIONS				
LTR	DESCRIPTION	DRAWN	DATE	APPROVED
1	NP-3037	ACM	02/05/09	

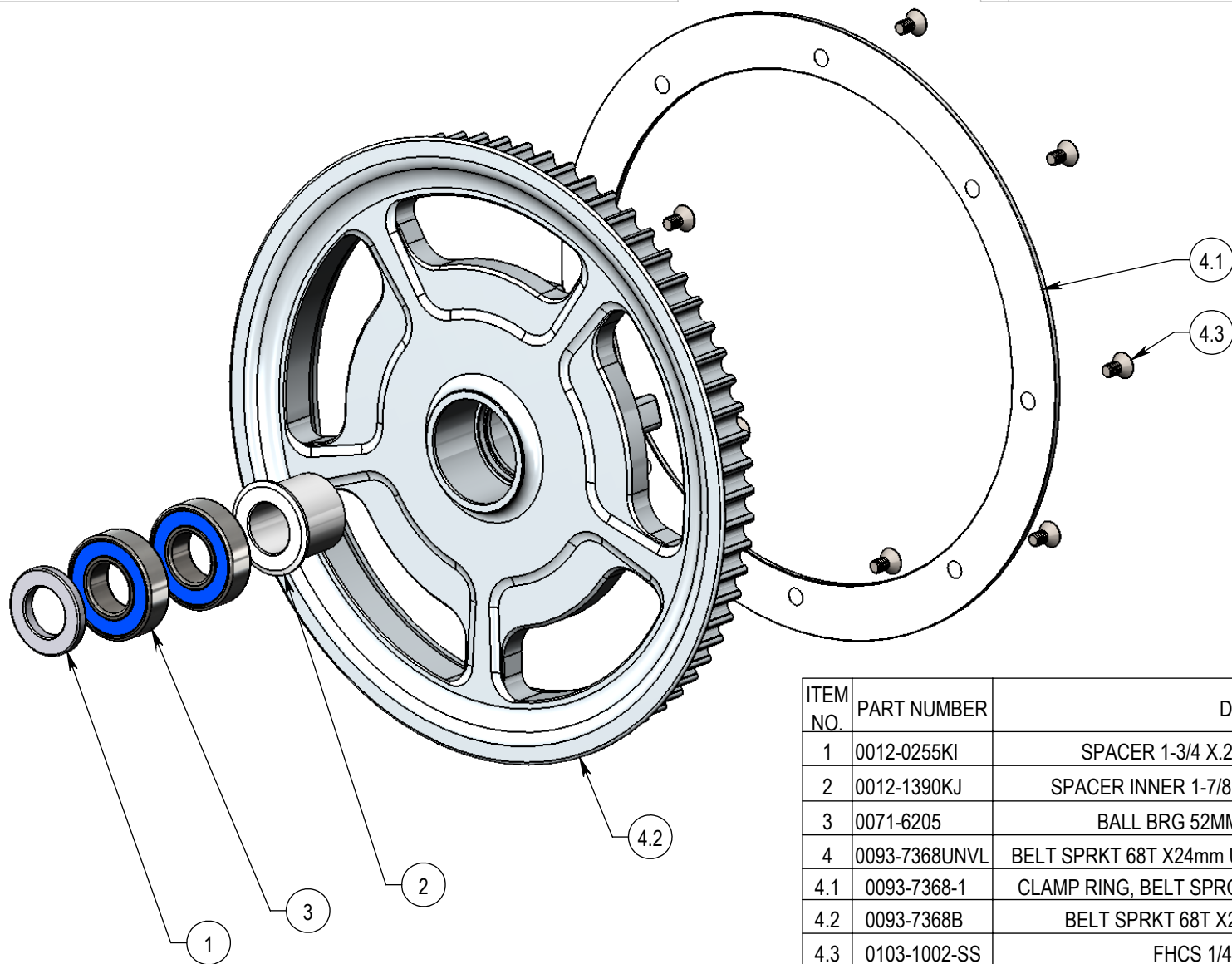

ITEM NO.	PART NUMBER	DESCRIPTION	QTY.
1	0012-0255KI	SPACER 1-3/4 X.255 X 25mm, FL 2009 #1269/70	1
2	0012-1390KJ	SPACER INNER 1-7/8 X1.39 X 25mm, FL 2009 #1269/70	1
3	0071-6205	BALL BRG 52MMx25x15 SEALED, 6205-2RS	2
4	0093-7368UNVL	BELT SPRKT 68T X24mm UNIVERSAL, COMP, FL 2009 #1269/70	1
4.1	0093-7368-1	CLAMP RING, BELT SPROCKET 68T, COMP, FL 2009 #1269/70	1
4.2	0093-7368B	BELT SPRKT 68T X24mm BLANK, FL 2009 #1269/70	1
4.3	0103-1002-SS	FHCS 1/4-20 X 1/2 STAINLESS	8

PARTS LIST

UNLESS OTHERWISE SPECIFIED
 1. DIMENSIONS ARE IN INCHES
 2. INTERPRET PER ASME Y14.5M-1994
 3. SURFACE TEXTURE SHALL BE 63
 4. REMOVE ALL BURRS AND SHARP EDGES .015

.XXXX = ±.0005
 .XXX = ±.005
 .XX = ±.01
 X/X = ±.03
 < = ±.5°

APPROVALS	DATE
DRAWN ACM	02/05/09
CHECKED	
RESP ENG	
MFG ENG	
QUAL ENG	
CAD GENERATED DRAWING, DO NOT MANUALLY UPDATE	
FILE: F:\ENG\SolidWorks\009\0093-7268UNVL.SLDDRW	



BELT SPRKT 68T X24mm UNIVERSAL ASSY, FL 2009 #1269/70

SIZE A 0093-7268UNVL REV. 1

SCALE 1:3 SHEET 1 OF 1

NOTES: UNLESS OTHERWISE SPECIFIED

1. INSPECT PER QA MANUAL.
2. DIMENSIONS APPLY BEFORE POLISHING, PLATING, OR COATING.

NEXT ASSY	MAKE MODEL YEAR	APPLICATION