

Congratulations, you have purchased the finest exhaust system available for your motorcycle. Your Vance & Hines exhaust is designed and crafted for performance, quality, and style. Please follow the instructions below, check exhaust system for missing or damaged parts and if you need any assistance please contact our technical support line (562) 921-7461.

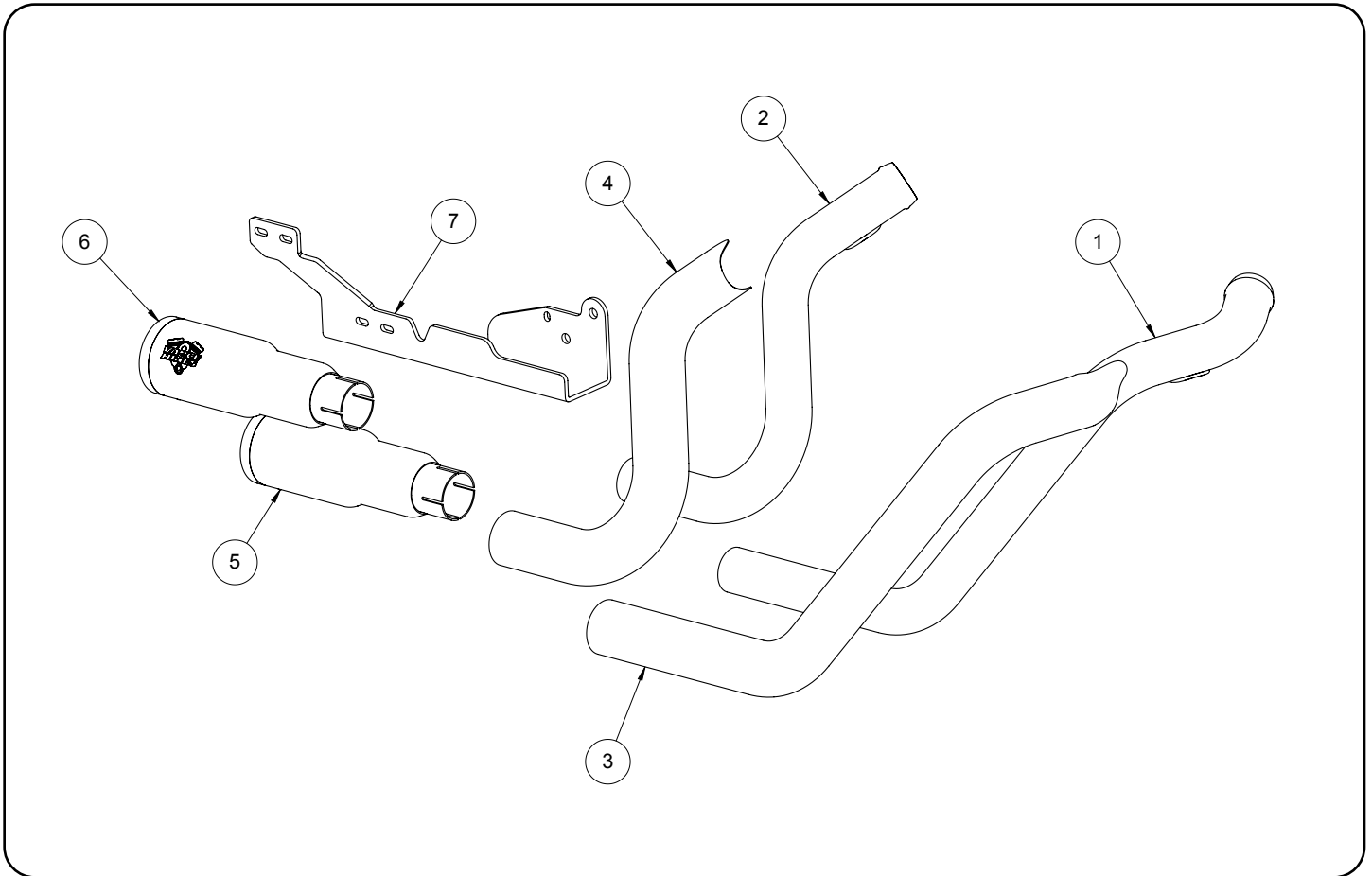

PARTS LIST

NO.	PART NO.	Description	Qty.
1	D866FC	Front Head Pipe	1
2	D867FC	Rear Head Pipe	1
3	D876HP	Front Heat Shield	1
4	D877HP	Rear Heat Shield	1
5	D686RP	Lower Muffler Can	1
6	D687RP	Upper Muffler Can	1
7	1123-P	Mounting Bracket	1
8	A758HW	Barrel Band Clamp	2
9	A270HW	Hose Clamp	6
10	A121HW	18mm Copper Washer	2
11	A213HW	18mm Plug-Zinc	2
12	A139HW	1/4-20 x 1/2 Flange Bolts	4
13	A288HW	Nylon Cable Tie	1

HARDWARE

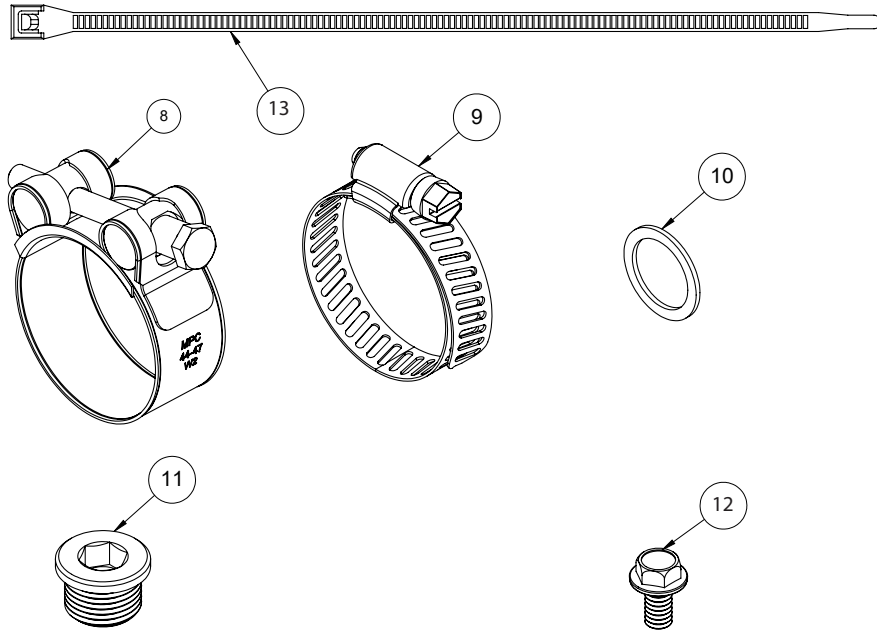

TOOLS REQUIRED

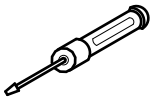

Flat Head Screwdriver

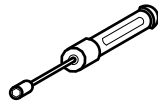

5/16 Nut Driver

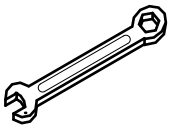

Combination Wrench:
3/8", 1/2", 9/16",
14mm, 19mm, 22mm

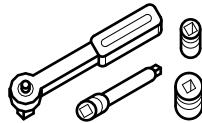

3/8" Drive Ratchet w/ 4"
extension 1/2", 9/16" Deep
Socket, 7/16" Deep Socket,
3/8", 10mm Socket

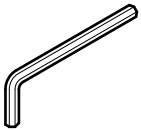

Allen Wrenches: 3/16",
5/16", 10mm
Torx: T30

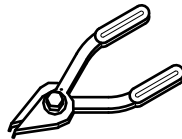

Snap Ring Pliers

STOCK EXHAUST SYSTEM REMOVAL

- 1.** If equipped, find and unplug the O2 sensor wires from the wiring harness. Feed the end of the wires through the frame so they are free from the motorcycle. Pay attention to the wire routing for re-installation.
- 2.** Loosen the heat shield clamps on both the front and rear head pipes. This allows for easier access to the head pipe mounting nuts.
- 3.** Remove the two head pipe mounting nuts from each flange, located at the cylinder head.
- 4.** Remove the clamp bolts which mounts the rear head pipe to the belt drive cover bracket.
- 5.** Remove the two bolts from each muffler body where they attach to the mounting bar. Carefully remove exhaust pipes from the motorcycle and set aside.
- 6.** Remove the belt drive cover and take the bracket off the rear cover bolt, this bracket will not be reused.
- 7.** Remove the brake rod at the rear eyelatch Remove the right side rider foot controls.
- 8.** Remove the three mounting bolts and washers attaching the exhaust mounting bar and save the hardware for reuse.
- 9.** Carefully remove the O2 sensors from the stock head pipes and save them for reuse with the new system.
- 10.** Carefully remove exhaust port flanges and circlips from the stock exhaust system using snapping pliers. Replace bent or damaged circlips.
- 11.** Check exhaust port gasket condition and replace if necessary. Harley-Davidson part number: 65324-83B.

VANCE & HINES EXHAUST INSTALLATION

1. Install the supplied mounting bracket, 1123-P, using the stock washers and bolts. Hand tighten only at this time.
2. Using a leveling tool, level the mounting bracket to the bottom tube of the frame. See **Figure 1**. **NOTE:** The mounting bracket may need adjustment to ensure the head pipes and mufflers are parallel.
3. Torque the mounting bracket bolts to 30-33 Ft./Lbs.
4. Reinstall the drive belt cover. Torque the 3/8" bolt to 30-33 FT./Lbs. and the 1/4" bolts to 80-120 In./Lbs.
5. Re-install at brake rod eyelet using removable thread locking compound (Loctite® 243 recommended). Torque to 120-180 In/Lbs. Re-install foot controls with A171HW-P spacer.
6. Remove head pipes and heat shields from their protective packaging. Place each heat shield on a non-abrasive surface such as a blanket or carpet. Using a pencil, lightly mark outside edge of each heat shield to show location of mounting clips where hose clamps will loop through. **NOTE:** Pencil marks can be erased if care is taken not to harm coating.
7. Lay the head pipes into heat shields and loosely install hose clamps by feeding tail end of the hose clamps into heat shield clips. Take note of screw head direction. **Figure 2.** Screw heads should be accessible when system is installed on motorcycle for adjustment purposes.
8. Apply a small amount of anti-seize compound to the threads of the O2 sensors and install them into the new head pipe. **NOTE: 2007 - 2013** models or models using 18mm wideband oxygen sensors install sensor directly into head pipe. **04-06 and models not using O2 sensors** install supplied 18mm plug and copper washer.
9. Install the exhaust port flanges and circlip from the stock system onto the new head pipes.
10. Using stock flange nuts, carefully install the head pipes into exhaust ports. Do not tighten the nuts at this time.
11. Slide the band clamps onto each muffler. Make sure that the nut on the clamps are accessible when installed on the bike. See **Figure 2**.
12. Install and slide the mufflers on one at this time. The muffler with the Vance & Hines logo must be installed on the upper rear head pipe. Hand tighten the muffler bodies to the bracket using the four 1/4-20 x 1/2 flange head bolts.
13. Tighten the band clamps from the mufflers to the headpipes.
14. Make sure to align the head pipes and mufflers then tighten the cylinder port exhaust flange nuts on front and rear cylinders. See **Figure 3**
15. Tighten the muffler mounting bolts.
16. Reconnect O2 sensors to the wire harness.
17. Be sure to tighten all hardware before starting the motorcycle.

FIGURE 1

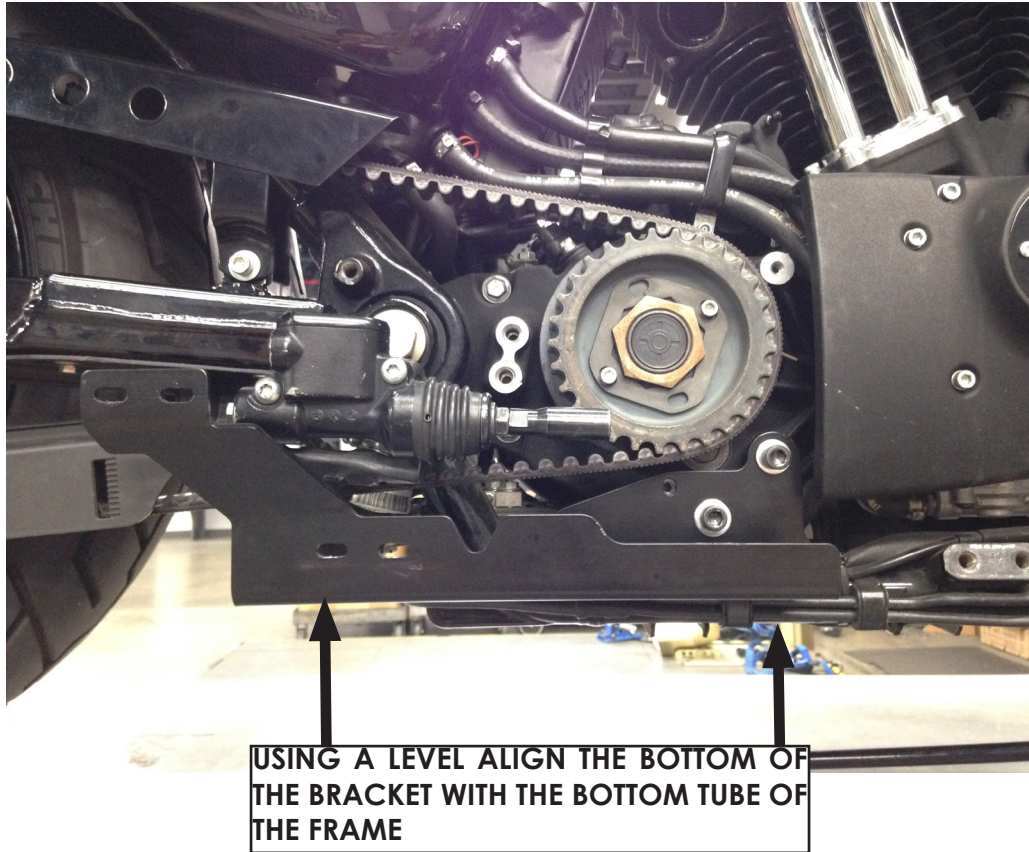

FIGURE 2

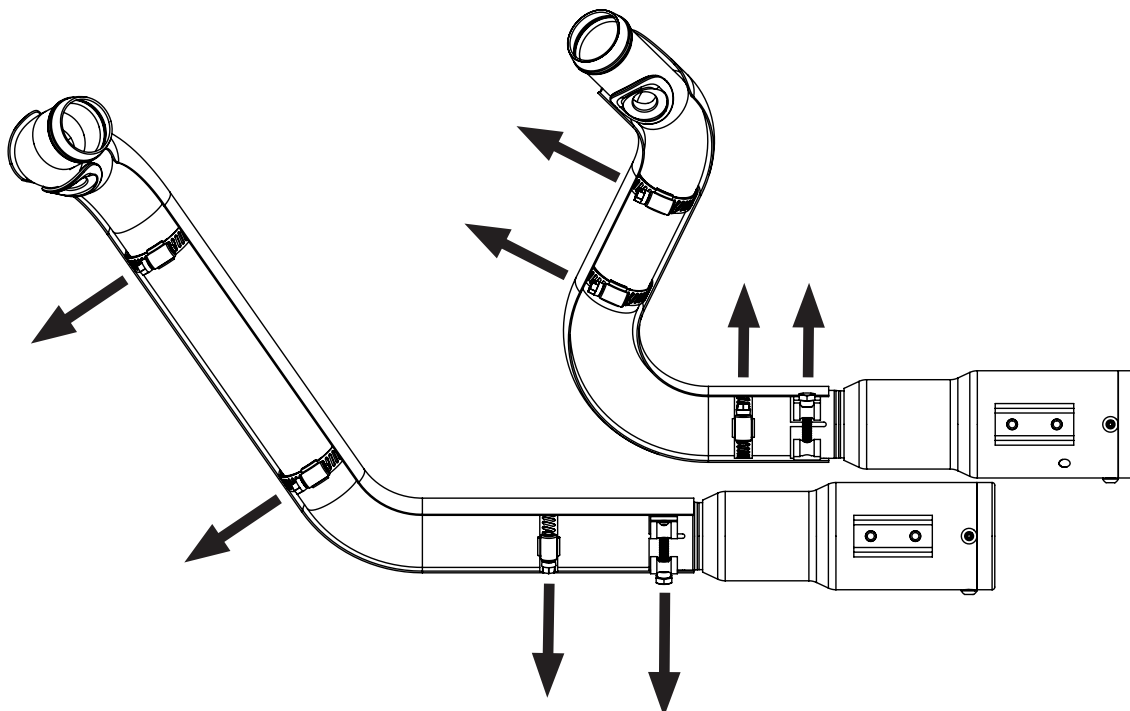

FIGURE 3



Emissions Notice:

In California, in order to meet Air Resources Board emissions requirements, certain aftermarket part applications have been identified as replacements, and others have received ARB Executive Orders. All other emissions related aftermarket parts are for competition use only. A list of replacement parts and EO parts, and corresponding fitment is provided at vanceandhines.com/California.

Warranty:

All Vance & Hines products are warranted against defects in material and workmanship for a period of 90 days. This warranty does not cover discoloration or rust. This warranty shall be limited to the repair or replacement of the product, which may be proven defective under normal use. Vance & Hines will not warranty any system that has been abused, misused, improperly installed or modified.

Dealers or distributors are not authorized to make dispositions binding upon Vance & Hines. Vance & Hines will not be responsible for any labor charges incurred in removing or replacing any system under warranty. A return authorization number and a copy of the original purchase invoice must accompany all returns. Parts returned without a return authorization may be refused.



Connect. Tune. Ride.

From the team that brought you The Fuelpak FP3, the best-selling ECU tuner in the world for Harley-Davidson motorcycles, the Vance & Hines FP4 is the most intuitive tuning tool on the market, giving you the power to control your motorcycle's tune and offers the best-in-industry support from our FP4 technicians, all from your smartphone.

- Download and Flash Maps
- Live Data Viewing
- Autotune Feature for Map Customization

Visit vanceandhines.com to learn more about FP4.

Qualified Manufacturer Declared 49-state Federal Emissions Compliant Part.



13861 ROSECRANS AVENUE / SANTA FE SPRINGS, CA 90670
SALES: (562) 921-5388
TECHNICAL: (562) 926-5291
FAX: (562) 802-0110

vanceandhines.com